

Week9 monday

Recall definition: A is **mapping reducible to** B means there is a computable function $f : \Sigma^* \rightarrow \Sigma^*$ such that for all strings x in Σ^* ,

$$x \in A \quad \text{if and only if} \quad f(x) \in B.$$

Notation: when A is mapping reducible to B , we write $A \leq_m B$.

Theorem (Sipser 5.23): If $A \leq_m B$ and A is undecidable, then B is undecidable.

Halting problem

$$HALT_{TM} = \{ \langle M, w \rangle \mid M \text{ is a Turing machine, } w \text{ is a string, and } M \text{ halts on } w \}$$

We will define a computable function that witnesses the mapping reduction $A_{TM} \leq_m HALT_{TM}$.

Using Theorem 5.23, we can then conclude that $HALT_{TM}$ is undecidable.

Define $F : \Sigma^* \rightarrow \Sigma^*$ by

$$F(x) = \begin{cases} const_{out} & \text{if } x \neq \langle M, w \rangle \text{ for any Turing machine } M \text{ and string } w \text{ over the alphabet of } M \\ \langle M', w \rangle & \text{if } x = \langle M, w \rangle \text{ for some Turing machine } M \text{ and string } w \text{ over the alphabet of } M. \end{cases}$$

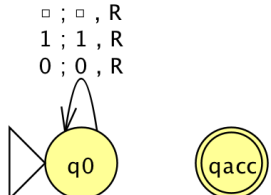

where $const_{out} = \langle \text{start state}, \varepsilon \rangle$ and M' is a Turing machine that computes like M except, if the computation ever were to go to a reject state, M' loops instead.

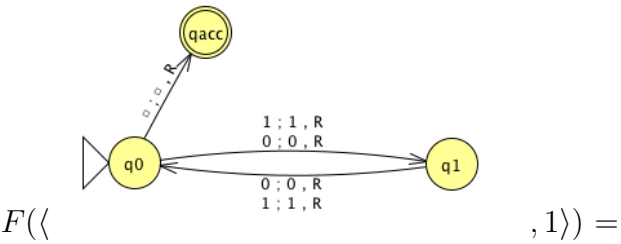
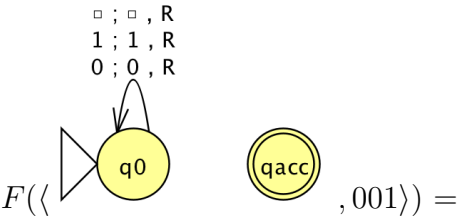

To use this function to prove that $A_{TM} \leq_m HALT_{TM}$, we need two claims:

Claim (1): F is computable

Claim (2): for every x , $x \in A_{TM}$ iff $F(x) \in HALT_{TM}$.

True or False: $\overline{A_{TM}} \leq_m \overline{HALT_{TM}}$

True or False: $HALT_{TM} \leq_m A_{TM}$.

Week9 wednesday

Recall: A is **mapping reducible to** B , written $A \leq_m B$, means there is a computable function $f : \Sigma^* \rightarrow \Sigma^*$ such that *for all* strings x in Σ^* ,

$$x \in A \quad \text{if and only if} \quad f(x) \in B.$$

Theorem (Sipser 5.28): If $A \leq_m B$ and B is recognizable, then A is recognizable.

Proof:

Corollary: If $A \leq_m B$ and A is unrecognizable, then B is unrecognizable.

Strategy:

(i) To prove that a recognizable language R is undecidable, prove that $A_{TM} \leq_m R$.

(ii) To prove that a co-recognizable language U is undecidable, prove that $\overline{A_{TM}} \leq_m U$, i.e. that $A_{TM} \leq_m \overline{U}$.

$$E_{TM} = \{\langle M \rangle \mid M \text{ is a Turing machine and } L(M) = \emptyset\}$$

Example string in E_{TM} is _____ . Example string not in E_{TM} is _____ .

E_{TM} is decidable / undecidable and recognizable / unrecognizable .

$\overline{E_{TM}}$ is decidable / undecidable and recognizable / unrecognizable .

Claim: _____ $\leq_m \overline{E_{TM}}$.

Proof: Need computable function $F : \Sigma^* \rightarrow \Sigma^*$ such that $x \in A_{TM}$ iff $F(x) \notin E_{TM}$. Define

$F =$ “ On input x ,

1. Type-check whether $x = \langle M, w \rangle$ for some TM M and string w . If so, move to step 2; if not, output
2. Construct the following machine M'_x :

3. Output $\langle M'_x \rangle$.”

Verifying correctness:

Input string	Output string
$\langle M, w \rangle$ where $w \in L(M)$	
$\langle M, w \rangle$ where $w \notin L(M)$	
x not encoding any pair of TM and string	

$$EQ_{TM} = \{\langle M, M' \rangle \mid M \text{ and } M' \text{ are both Turing machines and } L(M) = L(M')\}$$

Example string in EQ_{TM} is _____ . Example string not in EQ_{TM} is _____ .

EQ_{TM} is decidable / undecidable and recognizable / unrecognizable .

$\overline{EQ_{TM}}$ is decidable / undecidable and recognizable / unrecognizable .

To prove, show that _____ $\leq_m EQ_{TM}$ and that _____ $\leq_m \overline{EQ_{TM}}$.

Verifying correctness:

Input string	Output string
$\langle M, w \rangle$ where M halts on w	
$\langle M, w \rangle$ where M loops on w	
x not encoding any pair of TM and string	

Week9 friday

In practice, computers (and Turing machines) don't have infinite tape, and we can't afford to wait unboundedly long for an answer. "Decidable" isn't good enough - we want "Efficiently decidable".

For a given algorithm working on a given input, how long do we need to wait for an answer? How does the running time depend on the input in the worst-case? average-case? We expect to have to spend more time on computations with larger inputs.

A language is **recognizable** if _____

A language is **decidable** if _____

A language is **efficiently decidable** if _____

A function is **computable** if _____

A function is **efficiently computable** if _____

Definition (Sipser 7.1): For M a deterministic decider, its **running time** is the function $f : \mathbb{N} \rightarrow \mathbb{N}$ given by

$$f(n) = \max \text{ number of steps } M \text{ takes before halting, over all inputs of length } n$$

Definition (Sipser 7.7): For each function $t(n)$, the **time complexity class** $TIME(t(n))$, is defined by

$$TIME(t(n)) = \{L \mid L \text{ is decidable by a Turing machine with running time in } O(t(n))\}$$

An example of an element of $TIME(1)$ is

An example of an element of $TIME(n)$ is

Note: $TIME(1) \subseteq TIME(n) \subseteq TIME(n^2)$

Definition (Sipser 7.12) : P is the class of languages that are decidable in polynomial time on a deterministic 1-tape Turing machine

$$P = \bigcup_k TIME(n^k)$$

Compare to exponential time: brute-force search.

Theorem (Sipser 7.8): Let $t(n)$ be a function with $t(n) \geq n$. Then every $t(n)$ time deterministic multitape Turing machine has an equivalent $O(t^2(n))$ time deterministic 1-tape Turing machine.

Definition (Sipser 7.9): For N a nondeterministic decider. The **running time** of N is the function $f : \mathbb{N} \rightarrow \mathbb{N}$ given by

$$f(n) = \max \text{ number of steps } N \text{ takes on any branch before halting, over all inputs of length } n$$

Definition (Sipser 7.21): For each function $t(n)$, the **nondeterministic time complexity class** $NTIME(t(n))$, is defined by

$$NTIME(t(n)) = \{L \mid L \text{ is decidable by a nondeterministic Turing machine with running time in } O(t(n))\}$$

$$NP = \bigcup_k NTIME(n^k)$$

True or False: $TIME(n^2) \subseteq NTIME(n^2)$

True or False: $NTIME(n^2) \subseteq DTIME(n^2)$

Examples in P

Can't use nondeterminism; Can use multiple tapes; Often need to be "more clever" than naïve / brute force approach

$$PATH = \{\langle G, s, t \rangle \mid G \text{ is digraph with } n \text{ nodes there is path from } s \text{ to } t\}$$

Use breadth first search to show in P

$$RELPRIME = \{\langle x, y \rangle \mid x \text{ and } y \text{ are relatively prime integers}\}$$

Use Euclidean Algorithm to show in P

$$L(G) = \{w \mid w \text{ is generated by } G\}$$

(where G is a context-free grammar). Use dynamic programming to show in P .

Examples in NP

"Verifiable" i.e. NP, Can be decided by a nondeterministic TM in polynomial time, best known deterministic solution may be brute-force, solution can be verified by a deterministic TM in polynomial time.

$HAMPATH = \{\langle G, s, t \rangle \mid G \text{ is digraph with } n \text{ nodes, there is path from } s \text{ to } t \text{ that goes through every node exactly once}\}$

$VERTEX - COVER = \{\langle G, k \rangle \mid G \text{ is an undirected graph with } n \text{ nodes that has a } k\text{-node vertex cover}\}$

$CLIQUE = \{\langle G, k \rangle \mid G \text{ is an undirected graph with } n \text{ nodes that has a } k\text{-clique}\}$

$SAT = \{\langle X \rangle \mid X \text{ is a satisfiable Boolean formula with } n \text{ variables}\}$

Week8 monday

Theorem: A_{TM} is not Turing-decidable.

Proof: Suppose **towards a contradiction** that there is a Turing machine that decides A_{TM} . We call this presumed machine M_{ATM} .

By assumption, for every Turing machine M and every string w

- If $w \in L(M)$, then the computation of M_{ATM} on $\langle M, w \rangle$ _____
- If $w \notin L(M)$, then the computation of M_{ATM} on $\langle M, w \rangle$ _____

Define a **new** Turing machine using the high-level description:

$D =$ “ On input $\langle M \rangle$, where M is a Turing machine:

1. Run M_{ATM} on $\langle M, \langle M \rangle \rangle$.
2. If M_{ATM} accepts, reject; if M_{ATM} rejects, accept.”

Is D a Turing machine?

Is D a decider?

What is the result of the computation of D on $\langle D \rangle$?

Theorem (Sipser Theorem 4.22): A language is Turing-decidable if and only if both it and its complement are Turing-recognizable.

Proof, first direction: Suppose language L is Turing-decidable. WTS that both it and its complement are Turing-recognizable.

Proof, second direction: Suppose language L is Turing-recognizable, and so is its complement. WTS that L is Turing-decidable.

Give an example of a **decidable** set:

Give an example of a **recognizable undecidable** set:

Give an example of an **unrecognizable** set:

True or False: The class of Turing-decidable languages is closed under complementation?

Definition: A language L over an alphabet Σ is called **co-recognizable** if its complement, defined as $\Sigma^* \setminus L = \{x \in \Sigma^* \mid x \notin L\}$, is Turing-recognizable.

Notation: The complement of a set X is denoted with a superscript c , X^c , or an overline, \overline{X} .

Week8 wednesday

Mapping reduction

Motivation: Proving that A_{TM} is undecidable was hard. How can we leverage that work? Can we relate the decidability / undecidability of one problem to another?

If problem X is **no harder than** problem Y
... and if Y is easy,
... then X must be easy too.

If problem X is **no harder than** problem Y
... and if X is hard,
... then Y must be hard too.

“Problem X is no harder than problem Y ” means “Can answer questions about membership in X by converting them to questions about membership in Y ”.

Definition: A is **mapping reducible to** B means there is a computable function $f : \Sigma^* \rightarrow \Sigma^*$ such that for all strings x in Σ^* ,

$$x \in A \quad \text{if and only if} \quad f(x) \in B.$$

Notation: when A is mapping reducible to B , we write $A \leq_m B$.

Intuition: $A \leq_m B$ means A is no harder than B , i.e. that the level of difficulty of A is less than or equal the level of difficulty of B .

Computable functions

Definition: A function $f : \Sigma^* \rightarrow \Sigma^*$ is a **computable function** means there is some Turing machine such that, for each x , on input x the Turing machine halts with exactly $f(x)$ followed by all blanks on the tape

Examples of computable functions:

The function that maps a string to a string which is one character longer and whose value, when interpreted as a fixed-width binary representation of a nonnegative integer is twice the value of the input string (when interpreted as a fixed-width binary representation of a non-negative integer)

$$f_1 : \Sigma^* \rightarrow \Sigma^* \quad f_1(x) = x0$$

To prove f_1 is computable function, we define a Turing machine computing it.

High-level description

“On input w

1. Append 0 to w .
2. Halt.”

Implementation-level description

“On input w

1. Sweep read-write head to the right until find first blank cell.
2. Write 0.
3. Halt.”

Formal definition ($\{q_0, q_{acc}, q_{rej}\}, \{0, 1\}, \{0, 1, _ \}, \delta, q_0, q_{acc}, q_{rej}$) where δ is specified by the state diagram:

The function that maps a string to the result of repeating the string twice.

$$f_2 : \Sigma^* \rightarrow \Sigma^* \quad f_2(x) = xx$$

The function that maps strings that are not the codes of Turing machines to the empty string and that maps strings that code Turing machines to the code of the related Turing machine that acts like the Turing machine coded by the input, except that if this Turing machine coded by the input tries to reject, the new machine will go into a loop.

$$f_3 : \Sigma^* \rightarrow \Sigma^* \quad f_3(x) = \begin{cases} \varepsilon & \text{if } x \text{ is not the code of a TM} \\ \langle\langle Q \cup \{q_{trap}\}, \Sigma, \Gamma, \delta', q_0, q_{acc}, q_{rej} \rangle\rangle & \text{if } x = \langle\langle Q, \Sigma, \Gamma, \delta, q_0, q_{acc}, q_{rej} \rangle\rangle \end{cases}$$

where $q_{trap} \notin Q$ and

$$\delta'((q, x)) = \begin{cases} (r, y, d) & \text{if } q \in Q, x \in \Gamma, \delta((q, x)) = (r, y, d), \text{ and } r \neq q_{rej} \\ (q_{trap}, \sqcup, R) & \text{otherwise} \end{cases}$$

The function that maps strings that are not the codes of CFGs to the empty string and that maps strings that code CFGs to the code of a PDA that recognizes the language generated by the CFG.

Other examples?

Week8 friday

Recall definition: A is **mapping reducible to** B means there is a computable function $f : \Sigma^* \rightarrow \Sigma^*$ such that *for all* strings x in Σ^* ,

$$x \in A \quad \text{if and only if} \quad f(x) \in B.$$

Notation: when A is mapping reducible to B , we write $A \leq_m B$.

Intuition: $A \leq_m B$ means A is no harder than B , i.e. that the level of difficulty of A is less than or equal the level of difficulty of B .

Example: $A_{TM} \leq_m A_{TM}$

Example: $A_{DFA} \leq_m \{ww \mid w \in \{0,1\}^*\}$

Example: $\{0^i 1^j \mid i \geq 0, j \geq 0\} \leq_m A_{TM}$

Theorem (Sipser 5.22): If $A \leq_m B$ and B is decidable, then A is decidable.

Theorem (Sipser 5.23): If $A \leq_m B$ and A is undecidable, then B is undecidable.

Halting problem

$$HALT_{TM} = \{\langle M, w \rangle \mid M \text{ is a Turing machine, } w \text{ is a string, and } M \text{ halts on } w\}$$

Define $F : \Sigma^* \rightarrow \Sigma^*$ by

$$F(x) = \begin{cases} const_{out} & \text{if } x \neq \langle M, w \rangle \text{ for any Turing machine } M \text{ and string } w \text{ over the alphabet of } M \\ \langle M', w \rangle & \text{if } x = \langle M, w \rangle \text{ for some Turing machine } M \text{ and string } w \text{ over the alphabet of } M. \end{cases}$$

□ ; □ , R
1 ; 1 , R
0 ; 0 , R



where $const_{out} = \langle \square, \varepsilon \rangle$ and M' is a Turing machine that computes like M except, if the computation ever were to go to a reject state, M' loops instead.

□ ; □ , R
1 ; 1 , R
0 ; 0 , R

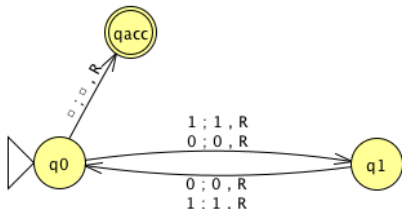

$F(\langle \square, 1 \rangle) =$

To use this function to prove that $A_{TM} \leq_m HALT_{TM}$, we need two claims:

Claim (1): F is computable

Claim (2): for every x , $x \in A_{TM}$ iff $F(x) \in HALT_{TM}$.

Week5 monday

To fully specify a PDA we could give its 6-tuple formal definition or we could give its input alphabet, stack alphabet, and state diagram. An informal description of a PDA is a step-by-step description of how its computations would process input strings; the reader should be able to reconstruct the state diagram or formal definition precisely from such a description. The informal description of a PDA can refer to some common modules or subroutines that are computable by PDAs:

- PDAs can “test for emptiness of stack” without providing details. *How?* We can always push a special end-of-stack symbol, \$, at the start, before processing any input, and then use this symbol as a flag.
- PDAs can “test for end of input” without providing details. *How?* We can transform a PDA to one where accepting states are only those reachable when there are no more input symbols.

Big picture: PDAs were motivated by wanting to add some memory of unbounded size to NFA. How do we accomplish a similar enhancement of regular expressions to get a syntactic model that is more expressive?

DFA, NFA, PDA: Machines process one input string at a time; the computation of a machine on its input string reads the input from left to right.

Regular expressions: Syntactic descriptions of all strings that match a particular pattern; the language described by a regular expression is built up recursively according to the expression’s syntax

Context-free grammars: Rules to produce one string at a time, adding characters from the middle, beginning, or end of the final string as the derivation proceeds.

Term	Typical symbol	Definition
Context-free grammar (CFG)	G	$G = (V, \Sigma, R, S)$
Variables	V	Finite set of symbols that represent phases in production pattern
Terminals	Σ	Alphabet of symbols of strings generated by CFG $V \cap \Sigma = \emptyset$
Rules	R	Each rule is $A \rightarrow u$ with $A \in V$ and $u \in (V \cup \Sigma)^*$
Start variable	S	Usually on LHS of first / topmost rule
Derivation	$S \Rightarrow \dots \Rightarrow w$	Sequence of substitutions in a CFG Start with start variable, apply one rule to one occurrence of a variable at a time
Language generated by the CFG G	$L(G)$	$\{w \in \Sigma^* \mid \text{there is derivation in } G \text{ that ends in } w\} = \{w \in \Sigma^* \mid S \Rightarrow^* w\}$
Context-free language		A language that is the language generated by some CFG
Sipser pages 102-103		

Examples of context-free grammars, derivations in those grammars, and the languages generated by those grammars

$G_1 = (\{S\}, \{0\}, R, S)$ with rules

$$S \rightarrow 0S$$

$$S \rightarrow 0$$

In $L(G_1) \dots$

Not in $L(G_1) \dots$

$G_2 = (\{S\}, \{0, 1\}, R, S)$

$$S \rightarrow 0S \mid 1S \mid \varepsilon$$

In $L(G_2) \dots$

Not in $L(G_2) \dots$

$(\{S, T\}, \{0, 1\}, R, S)$ with rules

$$S \rightarrow T1T1T1T$$

$$T \rightarrow 0T \mid 1T \mid \varepsilon$$

In $L(G_3)$...

Not in $L(G_3)$...

$G_4 = (\{A, B\}, \{0, 1\}, R, A)$ with rules

$$A \rightarrow 0A0 \mid 0A1 \mid 1A0 \mid 1A1 \mid 1$$

In $L(G_4)$...

Not in $L(G_4)$...

Extra practice: Is there a CFG G with $L(G) = \emptyset$?

Design a CFG to generate the language $\{abba\}$

$(\{S, T, V, W\}, \{a, b\}, \{S \rightarrow aT, T \rightarrow bV, V \rightarrow bW, W \rightarrow a\}, S)$

$(\{Q\}, \{a, b\}, \{Q \rightarrow abba\}, Q)$

$(\{X, Y\}, \{a, b\}, \{X \rightarrow aYa, Y \rightarrow bb\}, X)$

Design a CFG to generate the language $\{a^n b^n \mid n \geq 0\}$

Sample derivation:

Design a CFG to generate the language $\{a^i b^j \mid j \geq i \geq 0\}$

Sample derivation:

Week5 wednesday

Theorem 2.20: A language is generated by some context-free grammar if and only if it is recognized by some push-down automaton.

Definition: a language is called **context-free** if it is the language generated by a context-free grammar. The class of all context-free language over a given alphabet Σ is called **CFL**.

Consequences:

- Quick proof that every regular language is context free
- To prove closure of the class of context-free languages under a given operation, we can choose either of two modes of proof (via CFGs or PDAs) depending on which is easier

Over $\Sigma = \{a, b\}$, let $L = \{a^n b^m \mid n \neq m\}$. **Goal:** Prove L is context-free.

Suppose L_1 and L_2 are context-free languages over Σ . **Goal:** $L_1 \cup L_2$ is also context-free.

Approach 1: with PDAs

Let $M_1 = (Q_1, \Sigma, \Gamma_1, \delta_1, q_1, F_1)$ and $M_2 = (Q_2, \Sigma, \Gamma_2, \delta_2, q_2, F_2)$ be PDAs with $L(M_1) = L_1$ and $L(M_2) = L_2$.

Define $M =$

Approach 2: with CFGs

Let $G_1 = (V_1, \Sigma, R_1, S_1)$ and $G_2 = (V_2, \Sigma, R_2, S_2)$ be CFGs with $L(G_1) = L_1$ and $L(G_2) = L_2$.

Define $G =$

Suppose L_1 and L_2 are context-free languages over Σ . **Goal:** $L_1 \circ L_2$ is also context-free.

Approach 1: with PDAs

Let $M_1 = (Q_1, \Sigma, \Gamma_1, \delta_1, q_1, F_1)$ and $M_2 = (Q_2, \Sigma, \Gamma_2, \delta_2, q_2, F_2)$ be PDAs with $L(M_1) = L_1$ and $L(M_2) = L_2$.

Define $M =$

Approach 2: with CFGs

Let $G_1 = (V_1, \Sigma, R_1, S_1)$ and $G_2 = (V_2, \Sigma, R_2, S_2)$ be CFGs with $L(G_1) = L_1$ and $L(G_2) = L_2$.

Define $G =$

Summary

Over a fixed alphabet Σ , a language L is **regular**

- iff it is described by some regular expression
- iff it is recognized by some DFA
- iff it is recognized by some NFA

Over a fixed alphabet Σ , a language L is **context-free**

- iff it is generated by some CFG
- iff it is recognized by some PDA

Fact: Every regular language is a context-free language.

Fact: There are context-free languages that are not nonregular.

Fact: There are countably many regular languages.

Fact: There are countably infinitely many context-free languages.

Consequence: Most languages are **not** context-free!

Examples of non-context-free languages

$$\begin{aligned} &\{a^n b^n c^n \mid 0 \leq n, n \in \mathbb{Z}\} \\ &\{a^i b^j c^k \mid 0 \leq i \leq j \leq k, i \in \mathbb{Z}, j \in \mathbb{Z}, k \in \mathbb{Z}\} \\ &\{ww \mid w \in \{0, 1\}^*\} \end{aligned}$$

(Sipser Ex 2.36, Ex 2.37, 2.38)

There is a Pumping Lemma for CFL that can be used to prove a specific language is non-context-free: If A is a context-free language, there there is a number p where, if s is any string in A of length at least p , then s may be divided into five pieces $s = uvxyz$ where (1) for each $i \geq 0$, $uv^i xy^i z \in A$, (2) $|uv| > 0$, (3) $|vxy| \leq p$. *We will not go into the details of the proof or application of Pumping Lemma for CFLs this quarter.*

Week5 friday

A set X is said to be **closed** under an operation OP if, for any elements in X , applying OP to them gives an element in X .

True/False	Closure claim
True	The set of integers is closed under multiplication. $\forall x \forall y ((x \in \mathbb{Z} \wedge y \in \mathbb{Z}) \rightarrow xy \in \mathbb{Z})$
True	For each set A , the power set of A is closed under intersection. $\forall A_1 \forall A_2 ((A_1 \in \mathcal{P}(A) \wedge A_2 \in \mathcal{P}(A) \in \mathbb{Z}) \rightarrow A_1 \cap A_2 \in \mathcal{P}(A))$
	The class of regular languages over Σ is closed under complementation.
	The class of regular languages over Σ is closed under union.
	The class of regular languages over Σ is closed under intersection.
	The class of regular languages over Σ is closed under concatenation.
	The class of regular languages over Σ is closed under Kleene star.
	The class of context-free languages over Σ is closed under complementation.
	The class of context-free languages over Σ is closed under union.
	The class of context-free languages over Σ is closed under intersection.
	The class of context-free languages over Σ is closed under concatenation.
	The class of context-free languages over Σ is closed under Kleene star.

Assume $\Sigma = \{0, 1, \#\}$

Σ^*	Regular	/	nonregular and context-free	/	not context-free
$\{0^i \# 1^j \mid i \geq 0, j \geq 0\}$	Regular	/	nonregular and context-free	/	not context-free
$\{0^i 1^j \# 1^j 0^i \mid i \geq 0, j \geq 0\}$	Regular	/	nonregular and context-free	/	not context-free
$\{0^i 1^j \# 0^i 1^j \mid i \geq 0, j \geq 0\}$	Regular	/	nonregular and context-free	/	not context-free

Turing machines: unlimited read + write memory, unlimited time (computation can proceed without “consuming” input and can re-read symbols of input)

- Division between program (CPU, state diagram) and data
- Unbounded memory gives theoretical limit to what modern computation (including PCs, supercomputers, quantum computers) can achieve
- State diagram formulation is simple enough to reason about (and diagonalize against) while expressive enough to capture modern computation

For Turing machine $M = (Q, \Sigma, \Gamma, \delta, q_0, q_{accept}, q_{reject})$ the **computation** of M on a string w over Σ is:

- Read/write head starts at leftmost position on tape.
- Input string is written on $|w|$ -many leftmost cells of tape, rest of the tape cells have the blank symbol. **Tape alphabet** is Γ with $\sqcup \in \Gamma$ and $\Sigma \subseteq \Gamma$. The blank symbol $\sqcup \notin \Sigma$.
- Given current state of machine and current symbol being read at the tape head, the machine transitions to next state, writes a symbol to the current position of the tape head (overwriting existing symbol), and moves the tape head L or R (if possible). Formally, **transition function** is

$$\delta : Q \times \Gamma \rightarrow Q \times \Gamma \times \{L, R\}$$

- Computation ends if and when machine enters either the accept or the reject state. This is called **halting**. Note: $q_{accept} \neq q_{reject}$.

The **language recognized by the Turing machine** M , is

$$\{w \in \Sigma^* \mid \text{computation of } M \text{ on } w \text{ halts after entering the accept state}\} = \{w \in \Sigma^* \mid w \text{ is accepted by } M\}$$

An example Turing machine: $\Sigma =$

, $\Gamma =$

$\delta((q0, 0)) =$

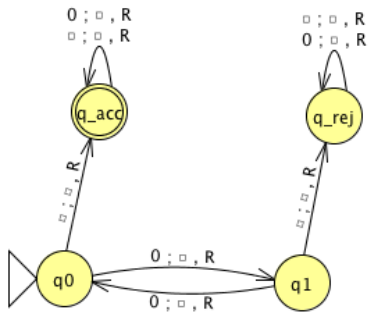

Formal definition:

Sample computation:

$q0 \downarrow$						
0	0	0	␣	␣	␣	␣

The language recognized by this machine is ...

Extra practice:

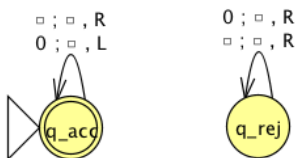

Formal definition:

Sample computation:

Conventions in state diagram of TM: $b \rightarrow R$ label means $b \rightarrow b, R$ and all arrows missing from diagram represent transitions with output $(q_{reject}, _, R)$

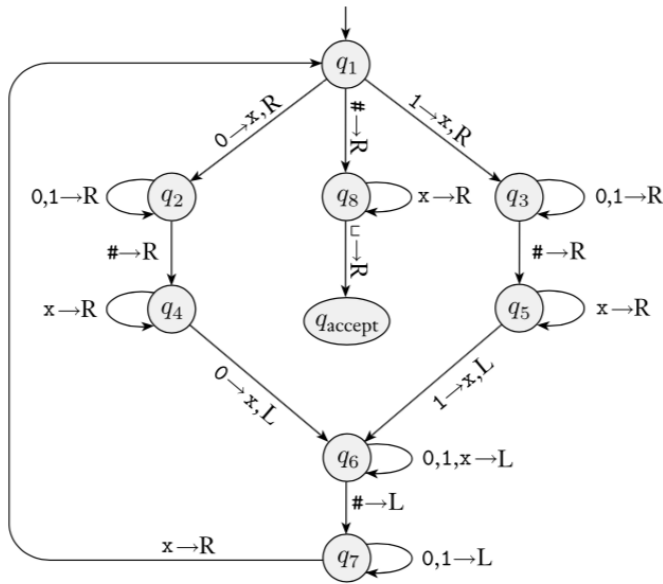

Computation on input string 01#01

$q_1 \downarrow$	0	1	#	0	1	$_$	$_$

Implementation level description of this machine:

Zig-zag across tape to corresponding positions on either side of # to check whether the characters in these positions agree. If they do not, or if there is no #, reject. If they do, cross them off.

Once all symbols to the left of the # are crossed off, check for any un-crossed-off symbols to the right of #; if there are any, reject; if there aren't, accept.

The language recognized by this machine is

$$\{w#w \mid w \in \{0, 1\}^*\}$$

Week4 monday

Recap so far: In DFA, the only memory available is in the states. Automata can only “remember” finitely far in the past and finitely much information, because they can have only finitely many states. If a computation path of a DFA visits the same state more than once, the machine can’t tell the difference between the first time and future times it visits this state. Thus, if a DFA accepts one long string, then it must accept (infinitely) many similar strings.

Definition A positive integer p is a **pumping length** of a language L over Σ means that, for each string $s \in \Sigma^*$, if $|s| \geq p$ and $s \in L$, then there are strings x, y, z such that

$$s = xyz$$

and

$$|y| > 0, \quad \text{for each } i \geq 0, xy^iz \in L, \quad \text{and} \quad |xy| \leq p.$$

Negation: A positive integer p is **not a pumping length** of a language L over Σ iff

$$\exists s (|s| \geq p \wedge s \in L \wedge \forall x \forall y \forall z ((s = xyz \wedge |y| > 0 \wedge |xy| \leq p) \rightarrow \exists i (i \geq 0 \wedge xy^iz \notin L)))$$

Informally:

Restating **Pumping Lemma**: If L is a regular language, then it has a pumping length.

Contrapositive: If L has no pumping length, then it is nonregular.

The Pumping Lemma *cannot* be used to prove that a language *is* regular.

The Pumping Lemma **can** be used to prove that a language *is not* regular.

Extra practice: Exercise 1.49 in the book.

Proof strategy: To prove that a language L is **not** regular,

- Consider an arbitrary positive integer p
- Prove that p is not a pumping length for L
- Conclude that L does not have *any* pumping length, and therefore it is not regular.

Example: $\Sigma = \{0, 1\}$, $L = \{0^n 1^n \mid n \geq 0\}$.

Fix p an arbitrary positive integer. List strings that are in L and have length greater than or equal to p :

Pick $s =$

Suppose $s = xyz$ with $|xy| \leq p$ and $|y| > 0$.

Then when $i =$ _____, $xy^i z =$

Example: $\Sigma = \{0, 1\}$, $L = \{ww^R \mid w \in \{0, 1\}^*\}$.

Fix p an arbitrary positive integer. List strings that are in L and have length greater than or equal to p :

Pick $s =$

Suppose $s = xyz$ with $|xy| \leq p$ and $|y| > 0$.

Then when $i =$, $xy^iz =$

Example: $\Sigma = \{0, 1\}$, $L = \{0^j1^k \mid j \geq k \geq 0\}$.

Fix p an arbitrary positive integer. List strings that are in L and have length greater than or equal to p :

Pick $s =$

Suppose $s = xyz$ with $|xy| \leq p$ and $|y| > 0$.

Then when $i =$, $xy^iz =$

Example: $\Sigma = \{0, 1\}$, $L = \{0^n1^m0^n \mid m, n \geq 0\}$.

Fix p an arbitrary positive integer. List strings that are in L and have length greater than or equal to p :

Pick $s =$

Suppose $s = xyz$ with $|xy| \leq p$ and $|y| > 0$.

Then when $i =$, $xy^iz =$

Week4 wednesday

Language	$s \in L$	$s \notin L$	Is the language regular or nonregular?
$\{a^n b^n \mid 0 \leq n \leq 5\}$			
$\{b^n a^n \mid n \geq 2\}$			
$\{a^m b^n \mid 0 \leq m \leq n\}$			
$\{a^m b^n \mid m \geq n + 3, n \geq 0\}$			
$\{b^m a^n \mid m \geq 1, n \geq 3\}$			
$\{w \in \{a, b\}^* \mid w = w^{\mathcal{R}}\}$			
$\{ww^{\mathcal{R}} \mid w \in \{a, b\}^*\}$			

Regular sets are not the end of the story

- Many nice / simple / important sets are not regular
- Limitation of the finite-state automaton model: Can't "count", Can only remember finitely far into the past, Can't backtrack, Must make decisions in "real-time"
- We know actual computers are more powerful than this model...

The **next** model of computation. Idea: allow some memory of unbounded size. How?

- To generalize regular expressions: **context-free grammars**
- To generalize NFA: **Pushdown automata**, which is like an NFA with access to a stack: Number of states is fixed, number of entries in stack is unbounded. At each step (1) Transition to new state based on current state, letter read, and top letter of stack, then (2) (Possibly) push or pop a letter to (or from) top of stack. Accept a string iff there is some sequence of states and some sequence of stack contents which helps the PDA processes the entire input string and ends in an accepting state.

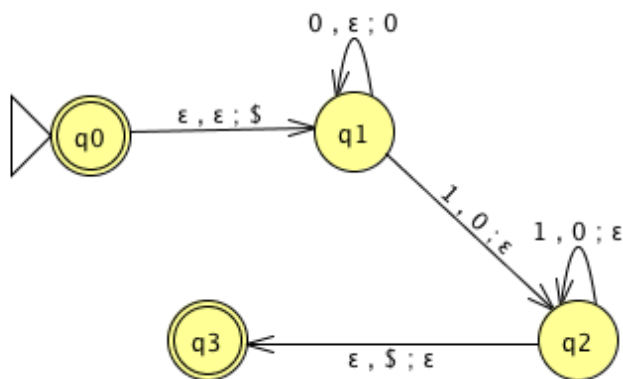

Trace the computation of this PDA on the input string 01.

Trace the computation of this PDA on the input string 011.

Week4 friday

Definition A **pushdown automaton** (PDA) is specified by a 6-tuple $(Q, \Sigma, \Gamma, \delta, q_0, F)$ where Q is the finite set of states, Σ is the input alphabet, Γ is the stack alphabet,

$$\delta : Q \times \Sigma_\epsilon \times \Gamma_\epsilon \rightarrow \mathcal{P}(Q \times \Gamma_\epsilon)$$

is the transition function, $q_0 \in Q$ is the start state, $F \subseteq Q$ is the set of accept states.

Formal definition

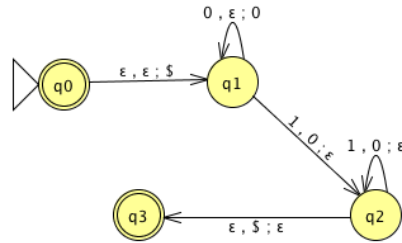

Draw the state diagram of a PDA with $\Sigma = \Gamma$.

Draw the state diagram of a PDA with $\Sigma \cap \Gamma = \emptyset$.

A PDA recognizing the set { } can be informally described as:

Read symbols from the input. As each 0 is read, push it onto the stack. As soon as 1s are seen, pop a 0 off the stack for each 1 read. If the stack becomes empty and there is exactly one 1 left to read, read that 1 and accept the input. If the stack becomes empty and there are either zero or more than one 1s left to read, or if the 1s are finished while the stack still contains 0s, or if any 0s appear in the input following 1s, reject the input.

State diagram for this PDA:

Consider the state diagram of a PDA with input alphabet Σ and stack alphabet Γ .

Label	means
$a, b; c$ when $a \in \Sigma, b \in \Gamma, c \in \Gamma$	
$a, \varepsilon; c$ when $a \in \Sigma, c \in \Gamma$	
$a, b; \varepsilon$ when $a \in \Sigma, b \in \Gamma$	
$a, \varepsilon; \varepsilon$ when $a \in \Sigma$	

How does the meaning change if a is replaced by ε ?

Note: alternate notation is to replace ; with \rightarrow

For the PDA state diagrams below, $\Sigma = \{0, 1\}$.

Mathematical description of language

State diagram of PDA recognizing language

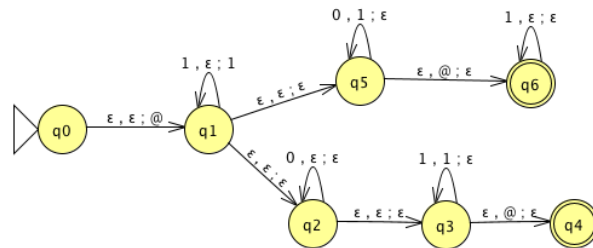
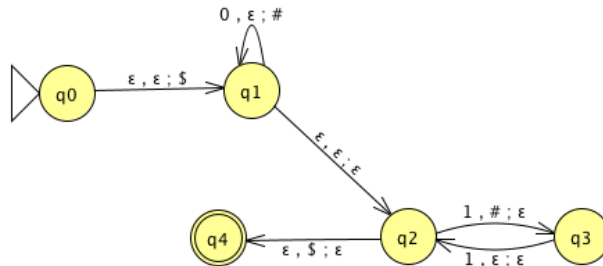

$$\{0^i 1^j 0^k \mid i, j, k \geq 0\}$$

Week6 monday

For Turing machine $M = (Q, \Sigma, \Gamma, \delta, q_0, q_{accept}, q_{reject})$ the **computation** of M on a string w over Σ is:

- Read/write head starts at leftmost position on tape.
- Input string is written on $|w|$ -many leftmost cells of tape, rest of the tape cells have the blank symbol. **Tape alphabet** is Γ with $\sqcup \in \Gamma$ and $\Sigma \subseteq \Gamma$. The blank symbol $\sqcup \notin \Sigma$.
- Given current state of machine and current symbol being read at the tape head, the machine transitions to next state, writes a symbol to the current position of the tape head (overwriting existing symbol), and moves the tape head L or R (if possible). Formally, **transition function** is

$$\delta : Q \times \Gamma \rightarrow Q \times \Gamma \times \{L, R\}$$

- Computation ends if and when machine enters either the accept or the reject state. This is called **halting**. Note: $q_{accept} \neq q_{reject}$.

The **language recognized by the Turing machine M** , is

$$\{w \in \Sigma^* \mid \text{computation of } M \text{ on } w \text{ halts after entering the accept state}\} = \{w \in \Sigma^* \mid w \text{ is accepted by } M\}$$

To define a Turing machine, we could give a

- **Formal definition**, namely the 7-tuple of parameters including set of states, input alphabet, tape alphabet, transition function, start state, accept state, and reject state; or,
- **Implementation-level definition**: English prose that describes the Turing machine head movements relative to contents of tape, and conditions for accepting / rejecting based on those contents.

Conventions for drawing state diagrams of Turing machines: (1) omit the reject state from the diagram (unless it's the start state), (2) any missing transitions in the state diagram have value (q_{reject}, \sqcup, R) .

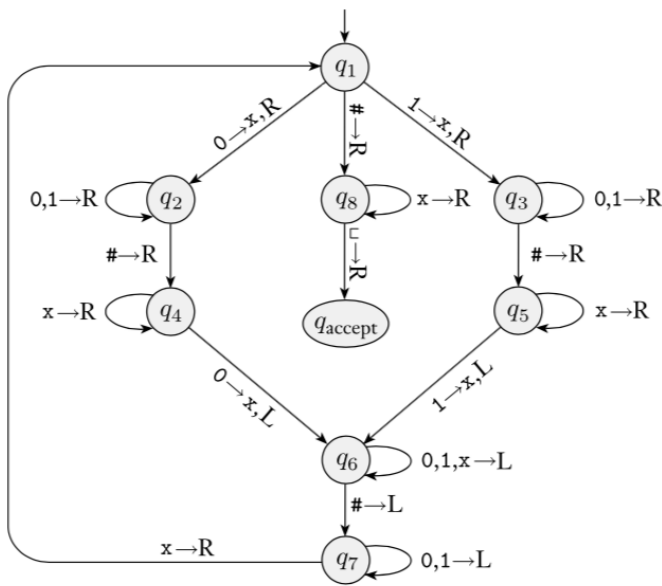

Computation on input string 01#01

q1 ↓						
0	1	#	0	1	␣	␣

Implementation level description of this machine:

Zig-zag across tape to corresponding positions on either side of # to check whether the characters in these positions agree. If they do not, or if there is no #, reject. If they do, cross them off.

Once all symbols to the left of the # are crossed off, check for any un-crossed-off symbols to the right of #; if there are any, reject; if there aren't, accept.

The language recognized by this machine is

$$\{w#w \mid w \in \{0, 1\}^*\}$$

A language L is **recognized by** a Turing machine M means



A Turing machine M **recognizes** a language L if means

A Turing machine M is a **decider** means

A language L is **decided by** a Turing machine M means

A Turing machine M **decides** a language L means

Fix $\Sigma = \{0, 1\}$, $\Gamma = \{0, 1, \sqcup\}$ for the Turing machines with the following state diagrams:

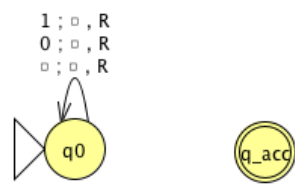
 <p>Implementation level description:</p> <p>Example of string accepted: Example of string rejected:</p> <p>Decider? Yes / No</p>	 <p>Implementation level description:</p> <p>Example of string accepted: Example of string rejected:</p> <p>Decider? Yes / No</p>
 <p>Implementation level description:</p> <p>Example of string accepted: Example of string rejected:</p> <p>Decider? Yes / No</p>	 <p>Implementation level description:</p> <p>Example of string accepted: Example of string rejected:</p> <p>Decider? Yes / No</p>

Week6 wednesday

Two models of computation are called **equally expressive** when every language recognizable with the first model is recognizable with the second, and vice versa.

True / False: NFAs and PDAs are equally expressive.

True / False: Regular expressions and CFGs are equally expressive.

*Some examples of models that are **equally expressive** with deterministic Turing machines:*

May-stay machines The May-stay machine model is the same as the usual Turing machine model, except that on each transition, the tape head may move L, move R, or Stay.

Formally: $(Q, \Sigma, \Gamma, \delta, q_0, q_{accept}, q_{reject})$ where

$$\delta : Q \times \Gamma \rightarrow Q \times \Gamma \times \{L, R, S\}$$

Claim: Turing machines and May-stay machines are equally expressive. *To prove ...*

To translate a standard TM to a may-stay machine:

To translate one of the may-stay machines to standard TM: any time TM would Stay, move right then left.

Formally: suppose $M_S = (Q, \Sigma, \Gamma, \delta, q_0, q_{acc}, q_{rej})$ has $\delta : Q \times \Gamma \rightarrow Q \times \Gamma \times \{L, R, S\}$. Define the Turing-machine

$$M_{new} = (\quad)$$

Multitape Turing machine A multitape Turing machine with k tapes can be formally represented as $(Q, \Sigma, \Gamma, \delta, q_0, q_{acc}, q_{rej})$ where Q is the finite set of states, Σ is the input alphabet with $\sqcup \notin \Sigma$, Γ is the tape alphabet with $\Sigma \subsetneq \Gamma$, $\delta : Q \times \Gamma^k \rightarrow Q \times \Gamma^k \times \{L, R\}^k$ (where k is the number of tapes)

If M is a standard TM, it is a 1-tape machine.

To translate a k -tape machine to a standard TM: Use a new symbol to separate the contents of each tape and keep track of location of head with special version of each tape symbol. Sipser Theorem 3.13

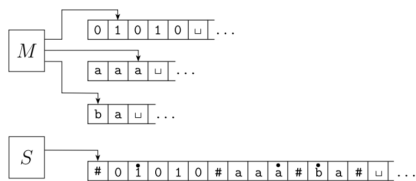

FIGURE 3.14 Representing three tapes with one

Extra practice: **Wikipedia Turing machine** Define a machine $(Q, \Gamma, b, \Sigma, q_0, F, \delta)$ where Q is the finite set of states Γ is the tape alphabet, $b \in \Gamma$ is the blank symbol, $\Sigma \subsetneq \Gamma$ is the input alphabet, $q_0 \in Q$ is the start state, $F \subseteq Q$ is the set of accept states, $\delta : (Q \setminus F) \times \Gamma \rightarrow Q \times \Gamma \times \{L, R\}$ is a partial transition function. If computation enters a state in F , it accepts. If computation enters a configuration where δ is not defined, it rejects. Hopcroft and Ullman, cited by Wikipedia

Enumerators Enumerators give a different model of computation where a language is **produced, one string at a time**, rather than recognized by accepting (or not) individual strings.

Each enumerator machine has finite state control, unlimited work tape, and a printer. The computation proceeds according to transition function; at any point machine may “send” a string to the printer.

$$E = (Q, \Sigma, \Gamma, \delta, q_0, q_{print})$$

Q is the finite set of states, Σ is the output alphabet, Γ is the tape alphabet ($\Sigma \subsetneq \Gamma, \sqcup \in \Gamma \setminus \Sigma$),

$$\delta : Q \times \Gamma \times \Gamma \rightarrow Q \times \Gamma \times \Gamma \times \{L, R\} \times \{L, R\}$$

where in state q , when the working tape is scanning character x and the printer tape is scanning character y , $\delta((q, x, y)) = (q', x', y', d_w, d_p)$ means transition to control state q' , write x' on the working tape, write y' on the printer tape, move in direction d_w on the working tape, and move in direction d_p on the printer tape. The computation starts in q_0 and each time the computation enters q_{print} the string from the leftmost edge of the printer tape to the first blank cell is considered to be printed.

The language **enumerated** by E , $L(E)$, is $\{w \in \Sigma^* \mid E \text{ eventually, at finite time, prints } w\}$.

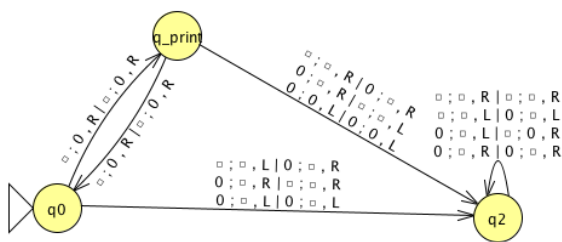

q_0						
\sqcup *	\sqcup	\sqcup	\sqcup	\sqcup	\sqcup	\sqcup
\sqcup *	\sqcup	\sqcup	\sqcup	\sqcup	\sqcup	\sqcup

Theorem 3.21 A language is Turing-recognizable iff some enumerator enumerates it. *Proof next time ...*

Week6 friday

To define a Turing machine, we could give a

- **Formal definition:** the 7-tuple of parameters including set of states, input alphabet, tape alphabet, transition function, start state, accept state, and reject state; or,
- **Implementation-level definition:** English prose that describes the Turing machine head movements relative to contents of tape, and conditions for accepting / rejecting based on those contents.
- **High-level description:** description of algorithm (precise sequence of instructions), without implementation details of machine. As part of this description, can “call” and run another TM as a subroutine.

Theorem 3.21 A language is Turing-recognizable iff some enumerator enumerates it.

Proof:

Assume L is enumerated by some enumerator, E , so $L = L(E)$. We’ll use E in a subroutine within a high-level description of a new Turing machine that we will build to recognize L .

Goal: build Turing machine M_E with $L(M_E) = L(E)$.

Define M_E as follows: $M_E =$ “On input w ,

1. Run E . For each string x printed by E .
2. Check if $x = w$. If so, accept (and halt); otherwise, continue.”

Assume L is Turing-recognizable and there is a Turing machine M with $L = L(M)$. We’ll use M in a subroutine within a high-level description of an enumerator that we will build to enumerate L .

Goal: build enumerator E_M with $L(E_M) = L(M)$.

Idea: check each string in turn to see if it is in L .

How? Run computation of M on each string. *But:* need to be careful about computations that don’t halt.

Recall String order for $\Sigma = \{0, 1\}$: $s_1 = \varepsilon$, $s_2 = 0$, $s_3 = 1$, $s_4 = 00$, $s_5 = 01$, $s_6 = 10$, $s_7 = 11$, $s_8 = 000$, ...

Define E_M as follows: $E_M =$ “ignore any input. Repeat the following for $i = 1, 2, 3, \dots$

1. Run the computations of M on s_1, s_2, \dots, s_i for (at most) i steps each
2. For each of these i computations that accept during the (at most) i steps, print out the accepted string.”

Nondeterministic Turing machine

At any point in the computation, the nondeterministic machine may proceed according to several possibilities: $(Q, \Sigma, \Gamma, \delta, q_0, q_{acc}, q_{rej})$ where

$$\delta : Q \times \Gamma \rightarrow \mathcal{P}(Q \times \Gamma \times \{L, R\})$$

The computation of a nondeterministic Turing machine is a tree with branching when the next step of the computation has multiple possibilities. A nondeterministic Turing machine accepts a string exactly when some branch of the computation tree enters the accept state.

Given a nondeterministic machine, we can use a 3-tape Turing machine to simulate it by doing a breadth-first search of computation tree: one tape is “read-only” input tape, one tape simulates the tape of the nondeterministic computation, and one tape tracks nondeterministic branching. Sipser page 178

Two models of computation are called **equally expressive** when every language recognizable with the first model is recognizable with the second, and vice versa.

Church-Turing Thesis (Sipser p. 183): The informal notion of algorithm is formalized completely and correctly by the formal definition of a Turing machine. In other words: all reasonably expressive models of computation are equally expressive with the standard Turing machine.

Claim: If two languages (over a fixed alphabet Σ) are Turing-recognizable, then their union is as well.

Proof using Turing machines:

Proof using nondeterministic Turing machines:

Proof using enumerators:

Week7 monday

	Suppose M is a TM that recognizes L	Suppose D is a TM that decides L	Suppose E is an enumerator that enumerates L
If string w is in L then ...			
If string w is not in L then ...			

Describing Turing machines (Sipser p. 185)

The Church-Turing thesis posits that each algorithm can be implemented by some Turing machine

High-level descriptions of Turing machine algorithms are written as indented text within quotation marks.

Stages of the algorithm are typically numbered consecutively.

The first line specifies the input to the machine, which must be a string. This string may be the encoding of some object or list of objects.

Notation: $\langle O \rangle$ is the string that encodes the object O . $\langle O_1, \dots, O_n \rangle$ is the string that encodes the list of objects O_1, \dots, O_n .

Assumption: There are Turing machines that can be called as subroutines to decode the string representations of common objects and interact with these objects as intended (data structures).

For example, since there are algorithms to answer each of the following questions, by Church-Turing thesis, there is a Turing machine that accepts exactly those strings for which the answer to the question is “yes”

- Does a string over $\{0, 1\}$ have even length?

- Does a string over $\{0, 1\}$ encode a string of ASCII characters?¹

- Does a DFA have a specific number of states?

- Do two NFAs have any state names in common?

- Do two CFGs have the same start variable?

¹An introduction to ASCII is available on the w3 tutorial here.

A **computational problem** is decidable iff language encoding its positive problem instances is decidable.

The computational problem “Does a specific DFA accept a given string?” is encoded by the language

$$\begin{aligned} & \{\text{representations of DFAs } M \text{ and strings } w \text{ such that } w \in L(M)\} \\ = & \{\langle M, w \rangle \mid M \text{ is a DFA, } w \text{ is a string, } w \in L(M)\} \end{aligned}$$

The computational problem “Is the language generated by a CFG empty?” is encoded by the language

$$\begin{aligned} & \{\text{representations of CFGs } G \text{ such that } L(G) = \emptyset\} \\ = & \{\langle G \rangle \mid G \text{ is a CFG, } L(G) = \emptyset\} \end{aligned}$$

The computational problem “Is the given Turing machine a decider?” is encoded by the language

$$\begin{aligned} & \{\text{representations of TMs } M \text{ such that } M \text{ halts on every input}\} \\ = & \{\langle M \rangle \mid M \text{ is a TM and for each string } w, M \text{ halts on } w\} \end{aligned}$$

Note: writing down the language encoding a computational problem is only the first step in determining if it's recognizable, decidable, or ...

Some classes of computational problems help us understand the differences between the machine models we've been studying:

Acceptance problem		
... for DFA	A_{DFA}	$\{\langle B, w \rangle \mid B \text{ is a DFA that accepts input string } w\}$
... for NFA	A_{NFA}	$\{\langle B, w \rangle \mid B \text{ is a NFA that accepts input string } w\}$
... for regular expressions	A_{REX}	$\{\langle R, w \rangle \mid R \text{ is a regular expression that generates input string } w\}$
... for CFG	A_{CFG}	$\{\langle G, w \rangle \mid G \text{ is a context-free grammar that generates input string } w\}$
... for PDA	A_{PDA}	$\{\langle B, w \rangle \mid B \text{ is a PDA that accepts input string } w\}$
Language emptiness testing		
... for DFA	E_{DFA}	$\{\langle A \rangle \mid A \text{ is a DFA and } L(A) = \emptyset\}$
... for NFA	E_{NFA}	$\{\langle A \rangle \mid A \text{ is a NFA and } L(A) = \emptyset\}$
... for regular expressions	E_{REX}	$\{\langle R \rangle \mid R \text{ is a regular expression and } L(R) = \emptyset\}$
... for CFG	E_{CFG}	$\{\langle G \rangle \mid G \text{ is a context-free grammar and } L(G) = \emptyset\}$
... for PDA	E_{PDA}	$\{\langle A \rangle \mid A \text{ is a PDA and } L(A) = \emptyset\}$
Language equality testing		
... for DFA	EQ_{DFA}	$\{\langle A, B \rangle \mid A \text{ and } B \text{ are DFAs and } L(A) = L(B)\}$
... for NFA	EQ_{NFA}	$\{\langle A, B \rangle \mid A \text{ and } B \text{ are NFAs and } L(A) = L(B)\}$
... for regular expressions	EQ_{REX}	$\{\langle R, R' \rangle \mid R \text{ and } R' \text{ are regular expressions and } L(R) = L(R')\}$
... for CFG	EQ_{CFG}	$\{\langle G, G' \rangle \mid G \text{ and } G' \text{ are CFGs and } L(G) = L(G')\}$
... for PDA	EQ_{PDA}	$\{\langle A, B \rangle \mid A \text{ and } B \text{ are PDAs and } L(A) = L(B)\}$
Sipser Section 4.1		

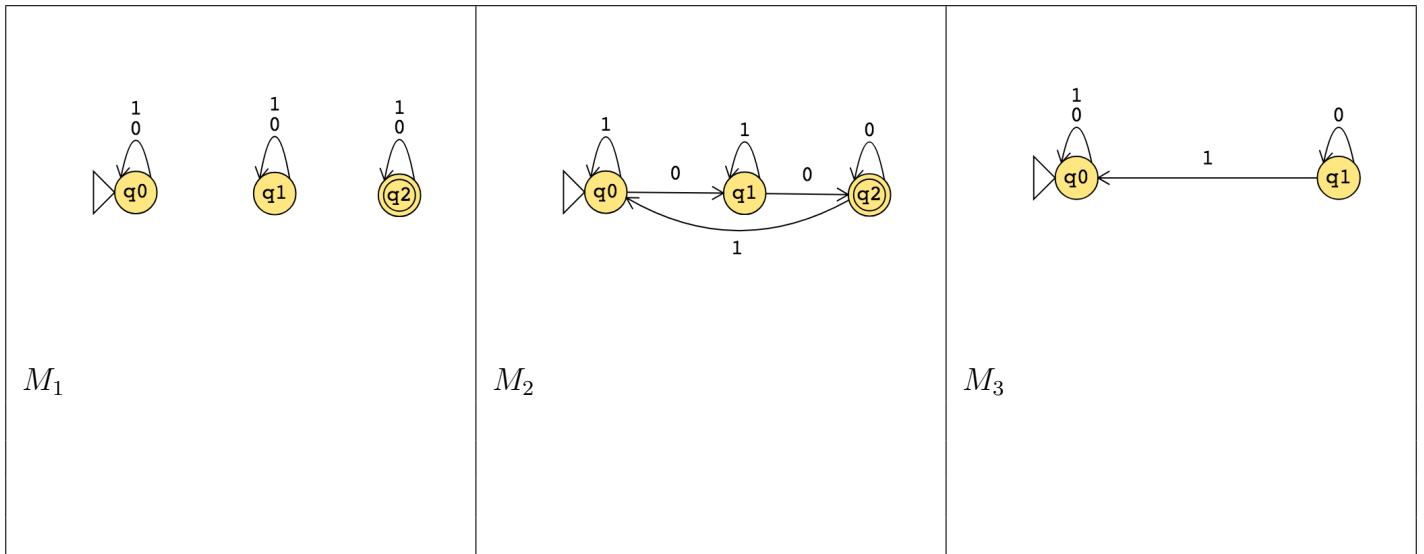

Example strings in A_{DFA}

Example strings in E_{DFA}

Example strings in EQ_{DFA}

Food for thought: which of the following computational problems are decidable: A_{DFA} ?, E_{DFA} ?, EQ_{DFA} ?

Week7 wednesday

Deciding a computational problem means building / defining a Turing machine that recognizes the language encoding the computational problem, and that is a decider.

Acceptance problem for ... $A...$ $\{\langle B, w \rangle \mid B \text{ is a } \dots \text{ that accepts input string } w\}$
Language emptiness testing for ... $E...$ $\{\langle A \rangle \mid A \text{ is a } \dots \text{ and } L(A) = \emptyset\}$
Language equality testing for ... $EQ...$ $\{\langle A, B \rangle \mid A \text{ and } B \text{ are } \dots \text{ and } L(A) = L(B)\}$
Sipser Section 4.1

$M_1 =$ “On input $\langle M, w \rangle$, where M is a DFA and w is a string:

0. Type check encoding to check input is correct type.
1. Simulate M on input w (by keeping track of states in M , transition function of M , etc.)
2. If the simulations ends in an accept state of M , accept. If it ends in a non-accept state of M , reject. ”

What is $L(M_1)$?

Is $L(M_1)$ a decider?

$M_2 =$ “On input $\langle M, w \rangle$ where M is a DFA and w is a string,

1. Run M on input w .
2. If M accepts, accept; if M rejects, reject.”

What is $L(M_2)$?

Is M_2 a decider?

$A_{REX} =$

$A_{NFA} =$

True / False: $A_{REX} = A_{NFA} = A_{DFA}$

True / False: $A_{REX} \cap A_{NFA} = \emptyset$, $A_{REX} \cap A_{DFA} = \emptyset$, $A_{DFA} \cap A_{NFA} = \emptyset$

A Turing machine that decides A_{NFA} is:

A Turing machine that decides A_{REX} is:

$M_3 =$ “On input $\langle M \rangle$ where M is a DFA,

1. For integer $i = 1, 2, \dots$
2. Let s_i be the i th string over the alphabet of M (ordered in string order).
3. Run M on input s_i .
4. If M accepts, _____ . If M rejects, increment i and keep going.”

Choose the correct option to help fill in the blank so that M_3 recognizes E_{DFA}

- A. accepts
- B. rejects
- C. loop for ever
- D. We can't fill in the blank in any way to make this work
- E. None of the above

$M_4 =$ “ On input $\langle M \rangle$ where M is a DFA,

1. Mark the start state of M .
2. Repeat until no new states get marked:
3. Loop over the states of M .
4. Mark any unmarked state that has an incoming edge from a marked state.
5. If no accept state of A is marked, _____; otherwise, _____” .

To build a Turing machine that decides EQ_{DFA} , notice that

$$L_1 = L_2 \quad \text{iff} \quad ((L_1 \cap \overline{L_2}) \cup (L_2 \cap \overline{L_1})) = \emptyset$$

There are no elements that are in one set and not the other

$M_{EQDFA} =$

Summary: We can use the decision procedures (Turing machines) of decidable problems as subroutines in other algorithms. For example, we have subroutines for deciding each of A_{DFA} , E_{DFA} , EQ_{DFA} . We can also use algorithms for known constructions as subroutines in other algorithms. For example, we have subroutines for: counting the number of states in a state diagram, counting the number of characters in an alphabet, converting DFA to a DFA recognizing the complement of the original language or a DFA recognizing the Kleene star of the original language, constructing a DFA or NFA from two DFA or NFA so that we have a machine recognizing the language of the union (or intersection, concatenation) of the languages of the original machines; converting regular expressions to equivalent DFA; converting DFA to equivalent regular expressions, etc.

Week7 friday

Acceptance problem

... for DFA	A_{DFA}	$\{\langle B, w \rangle \mid B \text{ is a DFA that accepts input string } w\}$
... for NFA	A_{NFA}	$\{\langle B, w \rangle \mid B \text{ is a NFA that accepts input string } w\}$
... for regular expressions	A_{REX}	$\{\langle R, w \rangle \mid R \text{ is a regular expression that generates input string } w\}$
... for CFG	A_{CFG}	$\{\langle G, w \rangle \mid G \text{ is a context-free grammar that generates input string } w\}$
... for PDA	A_{PDA}	$\{\langle B, w \rangle \mid B \text{ is a PDA that accepts input string } w\}$

Acceptance problemfor Turing machines $A_{TM} \{ \langle M, w \rangle \mid M \text{ is a Turing machine that accepts input string } w \}$ **Language emptiness testing**for Turing machines $E_{TM} \{ \langle M \rangle \mid M \text{ is a Turing machine and } L(M) = \emptyset \}$ **Language equality testing**for Turing machines $EQ_{TM} \{ \langle M_1, M_2 \rangle \mid M_1 \text{ and } M_2 \text{ are Turing machines and } L(M_1) = L(M_2) \}$

Sipser Section 4.1

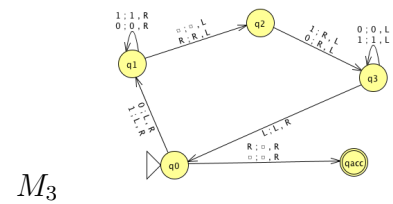
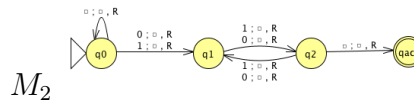
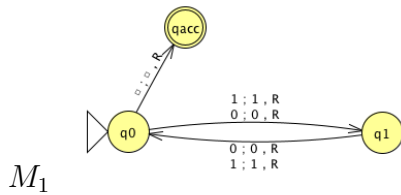
Example strings in A_{TM} Example strings in E_{TM} Example strings in EQ_{TM}

Theorem: A_{TM} is Turing-recognizable.

Strategy: To prove this theorem, we need to define a Turing machine R_{ATM} such that $L(R_{ATM}) = A_{TM}$.

Define $R_{ATM} =$ “

Proof of correctness:

We will show that A_{TM} is undecidable. *First, let's explore what that means.*

A **Turing-recognizable** language is a set of strings that is the language recognized by some Turing machine. We also say that such languages are recognizable.

A **Turing-decidable** language is a set of strings that is the language recognized by some decider. We also say that such languages are decidable.

An **unrecognizable** language is a language that is not Turing-recognizable.

An **undecidable** language is a language that is not Turing-decidable.

True or False: Any undecidable language is also unrecognizable.

True or False: Any unrecognizable language is also undecidable.

To prove that a computational problem is **decidable**, we find/ build a Turing machine that recognizes the language encoding the computational problem, and that is a decider.

How do we prove a specific problem is **not decidable**?

How would we even find such a computational problem?

Counting arguments for the existence of an undecidable language:

- The set of all Turing machines is countably infinite.
- Each Turing-recognizable language is associated with a Turing machine in a one-to-one relationship, so there can be no more Turing-recognizable languages than there are Turing machines.
- Since there are infinitely many Turing-recognizable languages (think of the singleton sets), there are countably infinitely many Turing-recognizable languages.
- Such the set of Turing-decidable languages is an infinite subset of the set of Turing-recognizable languages, the set of Turing-decidable languages is also countably infinite.

Since there are uncountably many languages (because $\mathcal{P}(\Sigma^*)$ is uncountable), there are uncountably many unrecognizable languages and there are uncountably many undecidable languages.

Thus, there's at least one undecidable language!

What's a specific example of a language that is unrecognizable or undecidable?

To prove that a language is undecidable, we need to prove that there is no Turing machine that decides it.

Key idea: proof by contradiction relying on self-referential disagreement.

Week3 friday

Theorem: For an alphabet Σ , For each language L over Σ ,

L is recognized by some DFA
iff
 L is recognized by some NFA
iff
 L is described by some regular expression

If (any, hence all) these conditions apply, L is called **regular**.

Prove or Disprove: There is some alphabet Σ for which there is some language recognized by an NFA but not by any DFA.

Prove or Disprove: There is some alphabet Σ for which there is some finite language not described by any regular expression over Σ .

Prove or Disprove: If a language is recognized by an NFA then the complement of this language is not recognized by any DFA.

Set	Cardinality
$\{0, 1\}$	
$\{0, 1\}^*$	
$\mathcal{P}(\{0, 1\})$	
The set of all languages over $\{0, 1\}$	
The set of all regular expressions over $\{0, 1\}$	
The set of all regular languages over $\{0, 1\}$	

Pumping Lemma (Sipser Theorem 1.70): If A is a regular language, then there is a number p (a *pumping length*) where, if s is any string in A of length at least p , then s may be divided into three pieces, $s = xyz$ such that

- $|y| > 0$
- for each $i \geq 0$, $xy^iz \in A$
- $|xy| \leq p$.

True or False: A pumping length for $A = \{0, 1\}^*$ is $p = 5$.

True or False: A pumping length for $A = \{1, 01, 001, 0001, 00001\}$ is $p = 4$.

True or False: A pumping length for $A = \{0^j1 \mid j \geq 0\}$ is $p = 3$.

True or False: For any language A , if p is a pumping length for A and $p' > p$, then p' is also a pumping length for A .

Week10 wednesday

Recall: For M a deterministic decider, its **running time** is the function $f : \mathbb{N} \rightarrow \mathbb{N}$ given by

$$f(n) = \text{max number of steps } M \text{ takes before halting, over all inputs of length } n$$

For each function $t(n)$, the **time complexity class** $TIME(t(n))$, is defined by

$$TIME(t(n)) = \{L \mid L \text{ is decidable by a Turing machine with running time in } O(t(n))\}$$

P is the class of languages that are decidable in polynomial time on a deterministic 1-tape Turing machine

$$P = \bigcup_k TIME(n^k)$$

Definition (Sipser 7.9): For N a nondeterministic decider. The **running time** of N is the function $f : \mathbb{N} \rightarrow \mathbb{N}$ given by

$$f(n) = \text{max number of steps } N \text{ takes on any branch before halting, over all inputs of length } n$$

Definition (Sipser 7.21): For each function $t(n)$, the **nondeterministic time complexity class** $NTIME(t(n))$, is defined by

$$NTIME(t(n)) = \{L \mid L \text{ is decidable by a nondeterministic Turing machine with running time in } O(t(n))\}$$

$$NP = \bigcup_k NTIME(n^k)$$

True or False: $TIME(n^2) \subseteq NTIME(n^2)$

True or False: $NTIME(n^2) \subseteq DTIME(n^2)$

Every problem in NP is decidable with an exponential-time algorithm

Nondeterministic approach: guess a possible solution, verify that it works.

Brute-force (worst-case exponential time) approach: iterate over all possible solutions, for each one, check if it works.

Examples in P

Can't use nondeterminism; Can use multiple tapes; Often need to be "more clever" than naïve / brute force approach

$$PATH = \{\langle G, s, t \rangle \mid G \text{ is digraph with } n \text{ nodes there is path from } s \text{ to } t\}$$

Use breadth first search to show in P

$$RELPRIME = \{\langle x, y \rangle \mid x \text{ and } y \text{ are relatively prime integers}\}$$

Use Euclidean Algorithm to show in P

$$L(G) = \{w \mid w \text{ is generated by } G\}$$

(where G is a context-free grammar). Use dynamic programming to show in P .

Examples in NP

"Verifiable" i.e. NP, Can be decided by a nondeterministic TM in polynomial time, best known deterministic solution may be brute-force, solution can be verified by a deterministic TM in polynomial time.

$$HAMPATH = \{\langle G, s, t \rangle \mid G \text{ is digraph with } n \text{ nodes,} \\ \text{there is path from } s \text{ to } t \text{ that goes through every node exactly once}\}$$

$$VERTEX - COVER = \{\langle G, k \rangle \mid G \text{ is an undirected graph with } n \text{ nodes that has a } k\text{-node vertex cover}\}$$

$$CLIQUE = \{\langle G, k \rangle \mid G \text{ is an undirected graph with } n \text{ nodes that has a } k\text{-clique}\}$$

$$SAT = \{\langle X \rangle \mid X \text{ is a satisfiable Boolean formula with } n \text{ variables}\}$$

Problems in P	Problems in NP
(Membership in any) regular language	Any problem in P
(Membership in any) context-free language	
A_{DFA}	SAT
E_{DFA}	$CLIQUE$
EQ_{DFA}	$VERTEX - COVER$
$PATH$	$HAMPATH$
$RELPRIME$...
...	

Million-dollar question: Is $P = NP$?

One approach to trying to answer it is to look for *hardest* problems in NP and then (1) if we can show that there are efficient algorithms for them, then we can get efficient algorithms for all problems in NP so $P = NP$, or (2) these problems might be good candidates for showing that there are problems in NP for which there are no efficient algorithms.

Definition (Sipser 7.29) Language A is **polynomial-time mapping reducible** to language B , written $A \leq_P B$, means there is a polynomial-time computable function $f : \Sigma^* \rightarrow \Sigma^*$ such that for every $x \in \Sigma^*$

$$x \in A \quad \text{iff} \quad f(x) \in B.$$

The function f is called the polynomial time reduction of A to B .

Theorem (Sipser 7.31): If $A \leq_P B$ and $B \in P$ then $A \in P$.

Proof:

Definition (Sipser 7.34; based in Stephen Cook and Leonid Levin's work in the 1970s): A language B is **NP-complete** means (1) B is in NP **and** (2) every language A in NP is polynomial time reducible to B .

Theorem (Sipser 7.35): If B is NP-complete and $B \in P$ then $P = NP$.

Proof:

3SAT: A literal is a Boolean variable (e.g. x) or a negated Boolean variable (e.g. \bar{x}). A Boolean formula is a **3cnf-formula** if it is a Boolean formula in conjunctive normal form (a conjunction of disjunctive clauses of literals) and each clause has three literals.

$$3SAT = \{\langle \phi \rangle \mid \phi \text{ is a satisfiable 3cnf-formula}\}$$

Example strings in $3SAT$

Example strings not in $3SAT$

Cook-Levin Theorem: $3SAT$ is NP -complete.

Are there other NP -complete problems? To prove that X is NP -complete

- *From scratch:* prove X is in NP and that all NP problems are polynomial-time reducible to X .
- *Using reduction:* prove X is in NP and that a known-to-be NP -complete problem is polynomial-time reducible to X .

CLIQUE: A k -**clique** in an undirected graph is a maximally connected subgraph with k nodes.

$$CLIQUE = \{\langle G, k \rangle \mid G \text{ is an undirected graph with a } k\text{-clique}\}$$

Example strings in $CLIQUE$

Example strings not in $CLIQUE$

Theorem (Sipser 7.32):

$$3SAT \leq_P CLIQUE$$

Given a Boolean formula in conjunctive normal form with k clauses and three literals per clause, we will map it to a graph so that the graph has a clique if the original formula is satisfiable and the graph does not have a clique if the original formula is not satisfiable.

The graph has $3k$ vertices (one for each literal in each clause) and an edge between all vertices except

- vertices for two literals in the same clause
- vertices for literals that are negations of one another

Example: $(x \vee \bar{y} \vee \bar{z}) \wedge (\bar{x} \vee y \vee z) \wedge (x \vee y \vee z)$

Week10 friday

Model of Computation	Class of Languages
<p>Deterministic finite automata: formal definition, how to design for a given language, how to describe language of a machine? Nondeterministic finite automata: formal definition, how to design for a given language, how to describe language of a machine? Regular expressions: formal definition, how to design for a given language, how to describe language of expression? <i>Also:</i> converting between different models.</p>	<p>Class of regular languages: what are the closure properties of this class? which languages are not in the class? using pumping lemma to prove nonregularity.</p>
<p>Push-down automata: formal definition, how to design for a given language, how to describe language of a machine? Context-free grammars: formal definition, how to design for a given language, how to describe language of a grammar?</p>	<p>Class of context-free languages: what are the closure properties of this class? which languages are not in the class?</p>
<p>Turing machines that always halt in polynomial time</p> <p>Nondeterministic Turing machines that always halt in polynomial time</p>	<p>P</p> <p>NP</p>
<p>Deciders (Turing machines that always halt): formal definition, how to design for a given language, how to describe language of a machine?</p>	<p>Class of decidable languages: what are the closure properties of this class? which languages are not in the class? using diagonalization and mapping reduction to show undecidability</p>
<p>Turing machines formal definition, how to design for a given language, how to describe language of a machine?</p>	<p>Class of recognizable languages: what are the closure properties of this class? which languages are not in the class? using closure and mapping reduction to show unrecognizability</p>

Given a language, prove it is regular

Strategy 1: construct DFA recognizing the language and prove it works.

Strategy 2: construct NFA recognizing the language and prove it works.

Strategy 3: construct regular expression recognizing the language and prove it works.

“Prove it works” means ...

Example: $L = \{w \in \{0, 1\}^* \mid w \text{ has odd number of 1s or starts with } 0\}$

Using NFA

Using regular expressions

Example: Select all and only the options that result in a true statement: “To show a language A is not regular, we can...”

- a. Show A is finite
- b. Show there is a CFG generating A
- c. Show A has no pumping length
- d. Show A is undecidable

Example: What is the language generated by the CFG with rules

$$S \rightarrow aSb \mid bY \mid Ya$$

$$Y \rightarrow bY \mid Ya \mid \varepsilon$$

Example: Prove that the language $T = \{\langle M \rangle \mid M \text{ is a Turing machine and } L(M) \text{ is infinite}\}$ is undecidable.

Example: Prove that the class of decidable languages is closed under concatenation.